



TEDELTA

TECNICA DEL TAPADO S.A.U

MAGNETIC CAPPING HEAD

TEDELTA C.M. 706 T.R.

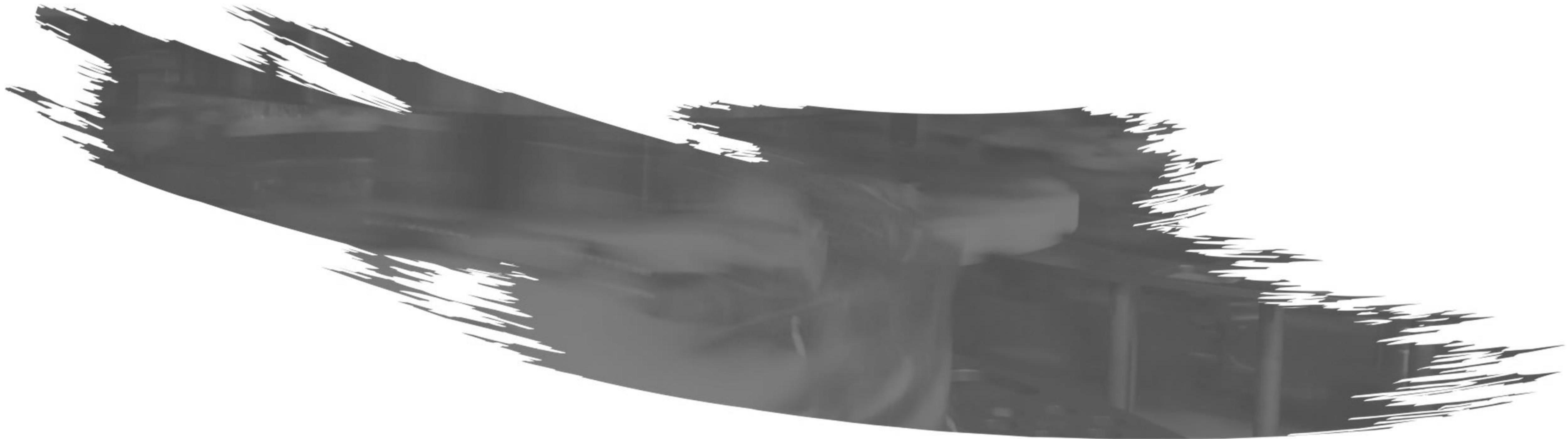

The soul of our machines.

Our commitment in capping technology, allows us to offer tailor made capping Turrets to filler equipment manufacturers and complete capping systems to the end user. More than 40 years of experience, gives us total control of our design and manufacturing of our equipment; Cappers, turrets and capping heads makes us the one and only Spaniard capper manufacturer.

CAPPING HEAD



ROLL-ON



MAGNETICS



PUSH-ON



HYSTERESIS



SERVO-HEAD



DECAPPING

Specialized in
complete capping systems
for the bottling and packaging industries

Technological Accuracy

•In TEDELTA we have specialized in the search and improvement of capping system being the own development heads that are continuously improved by our R & D department, in addition to making new designs adapted to the needs of our clients according to the caps to apply .

•The capping heads, are the soul of our machines, getting together in the same head design with high precision, technologically advanced, functionality, and aesthetic sense.

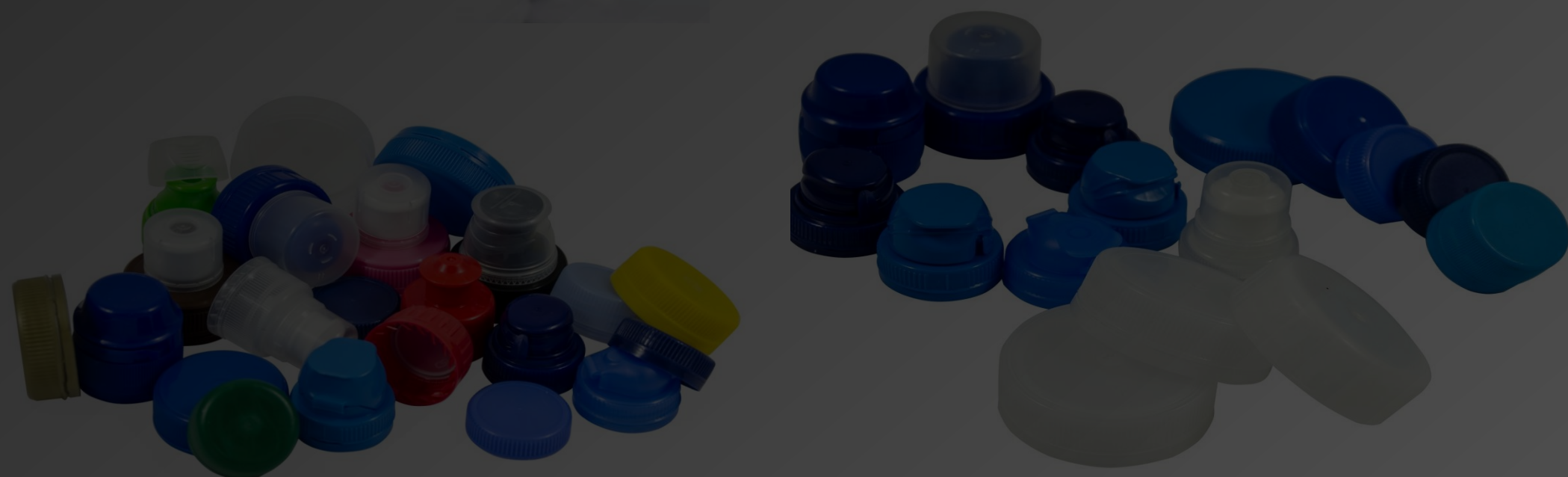

MAGNETICS CAPPING HEADS

TEDELTA C.M. 706 T.R.

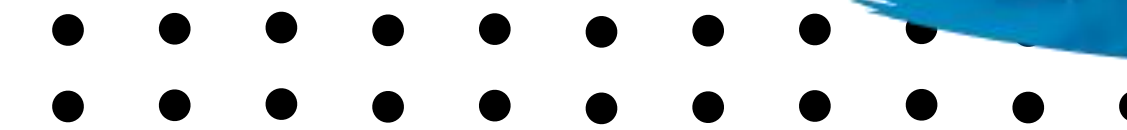

Objetivo

Capping head designed for a perfect sealing of screw-on plastic closures, pretreated, flat caps, flip-top caps, special caps...



Descripción

- Depending on the type of plastic cap possibility to use rigid chuck or with gripping system .
- Magnetic clutch design allows the effective and constant torque to the speed required by the customer.
- It has been designed for a wide range of screw-on capping applications.
- Adjustment of torque with optical reading
- Adjustment of the torque without the use of special tools.
- Outside spring allows top load adjustment easily
- Quick-change chucks, no tools
- OPTIONAL: Quick-change chucks and torque settings

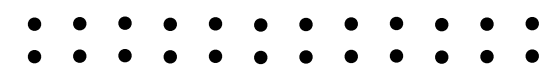

MAGNETICS CAPPING HEADS

TEDELTA C.M. 706 T.R.

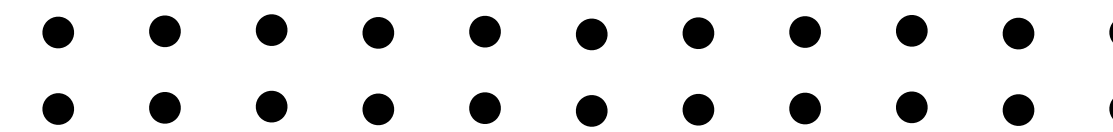

- Adjustment of torque with optical reading.
- Outside spring allows top load adjustment easily.
- Quick-change chucks, no tools.



Magnetic clutch design allows the effective and constant torque to the speed required by the customer.

- Adjustment of the torque without the use of special tools.

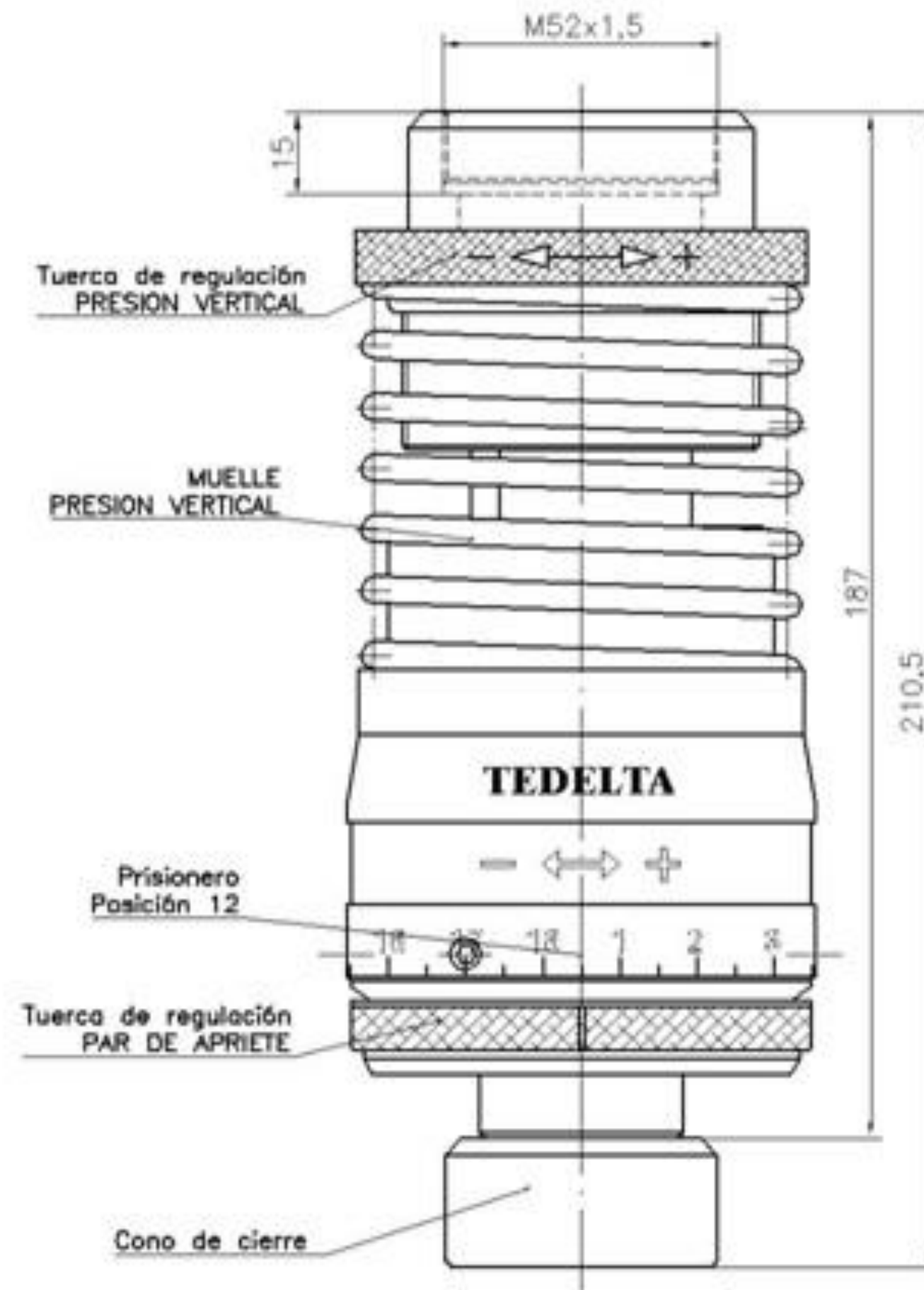

CABEZAL MAGNETICO TEDELTA-CM-706-TR
VERSION "TRANSFER" (Pick and Place)

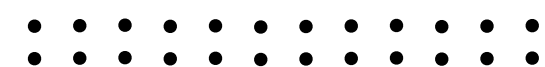

TEDELTA C.M. 706 T.R.

QUICK ADJUSTEMENT

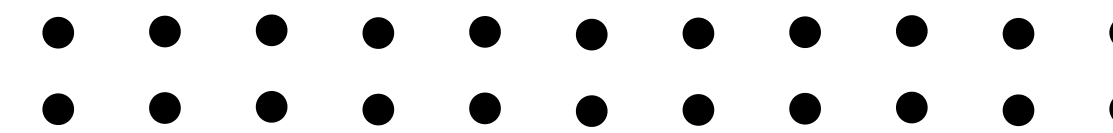

- Capping head easy and quick torque adjustment without tools.
- No need locking screws.
- 3 to 35 lbx inn target torque range.
- 360° torque adjuster rotation.
- Torque scale.
- Top load scale

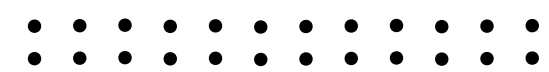
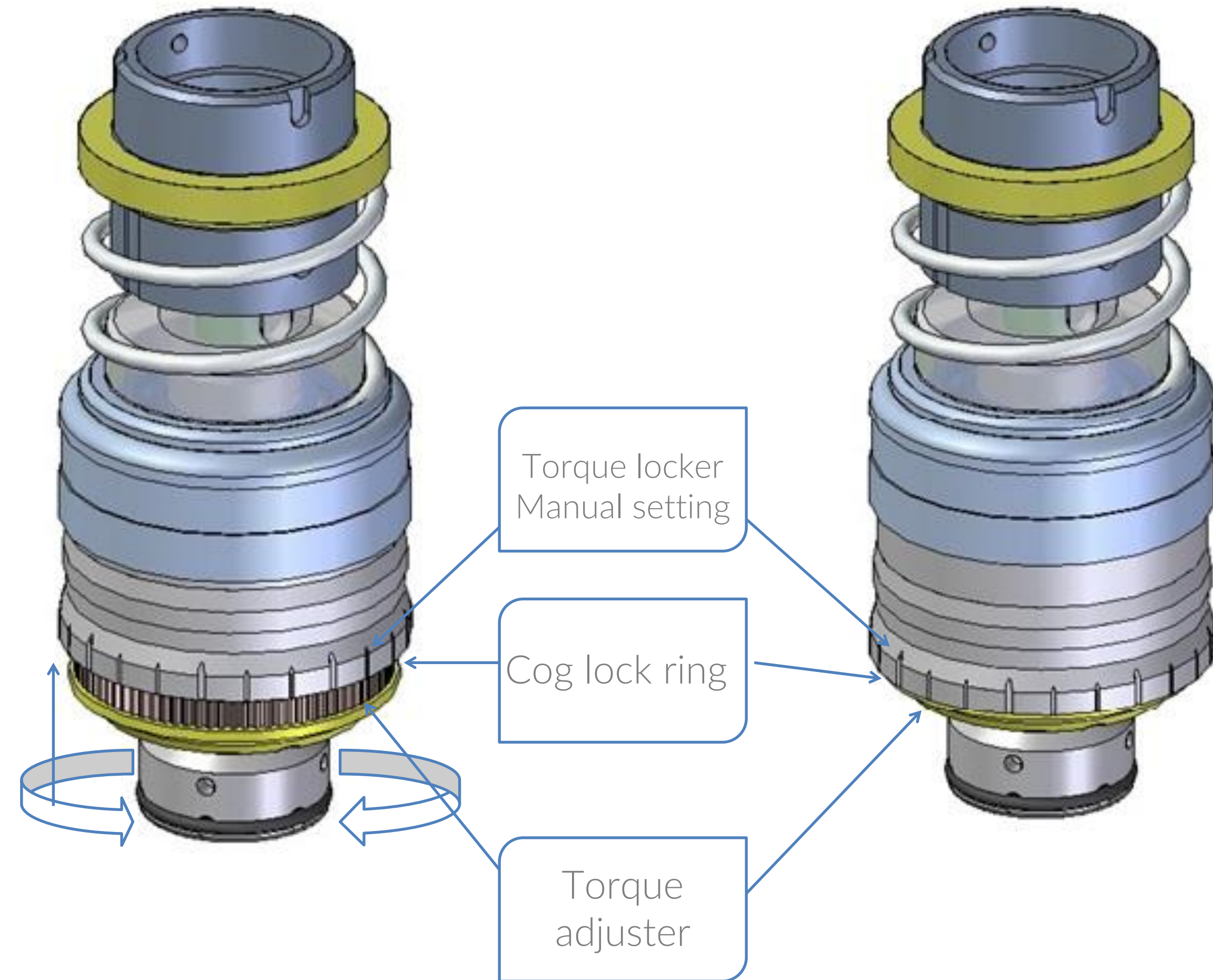

TEDELTA C.M. 706 T.R.

TORQUE SETTING

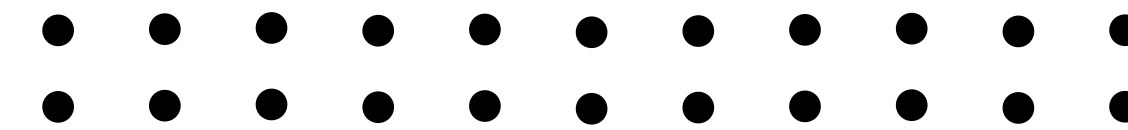

EASY AND FAST WAY TO ADJUST THE TORQUE WITHOUT SCREWS AND TOOLS.

1. Move up the torque locker manual setting.
- 2.- Adjust the torque with the torque adjuster.
- 3.- Leave the torque locker and fit the two cog lock rings.

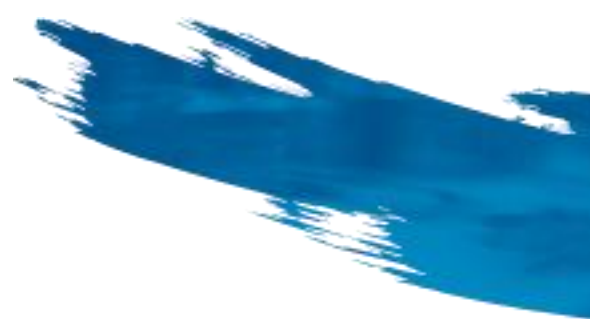
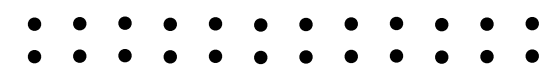
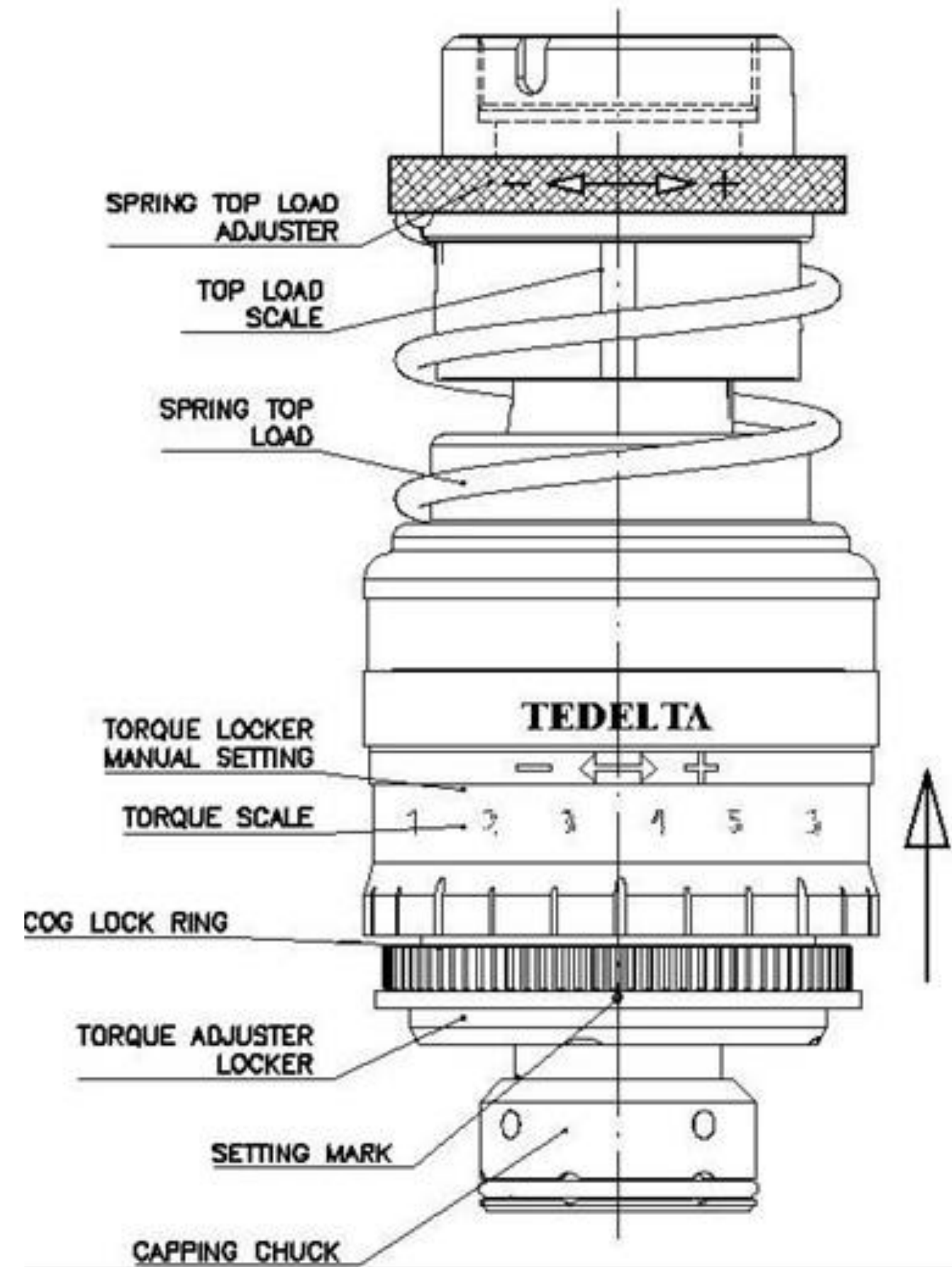

TEDELTA C.M. 706 T.R.

TORQUE SETTING

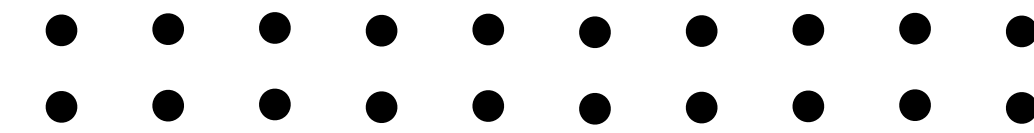

TORQUE OPERATION

1. Move up the torque locker .
2. Adjust the torque.
3. Move down the torque locker.

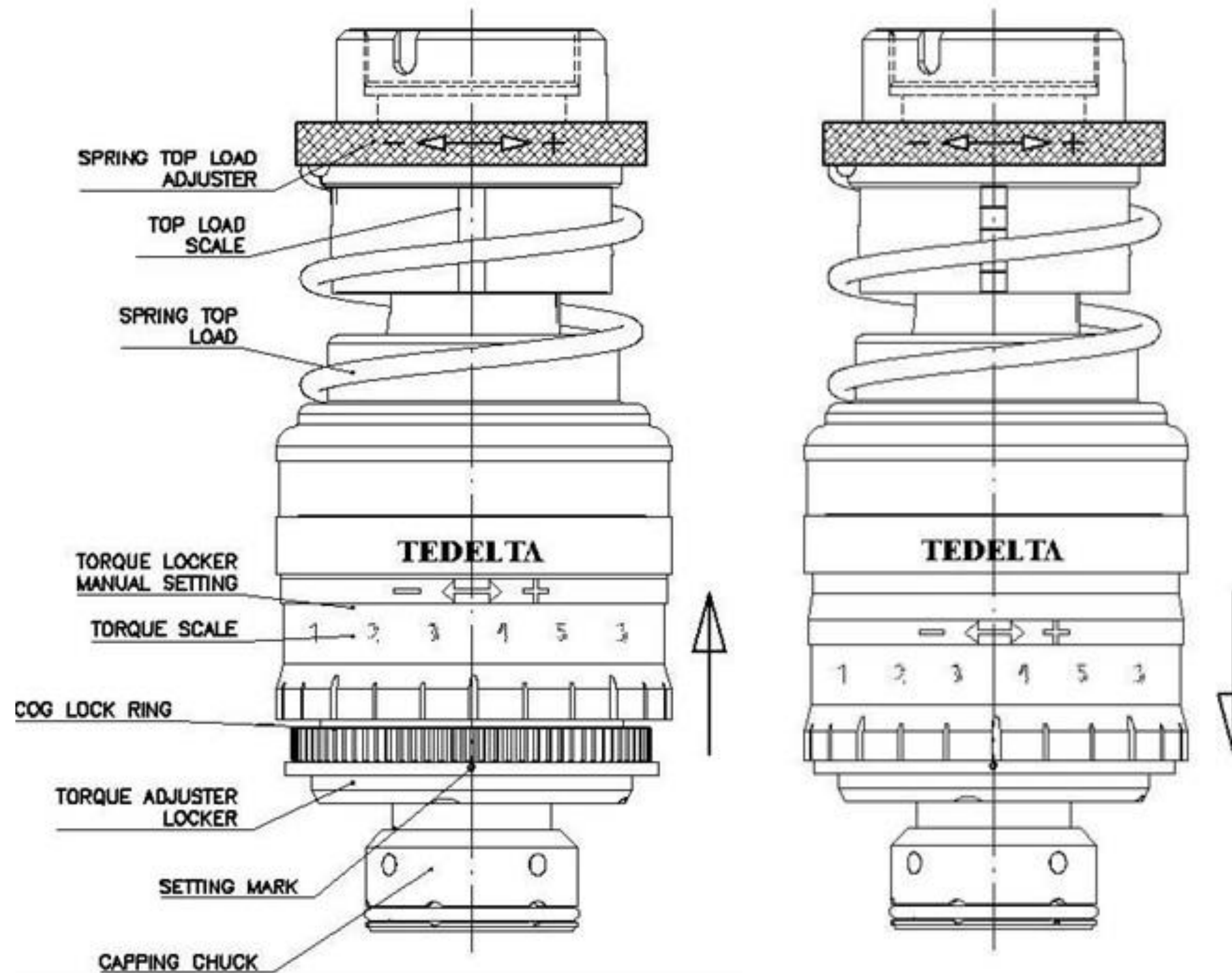

QUICK CHANGE GRIPPING CAPPING CHUCKS

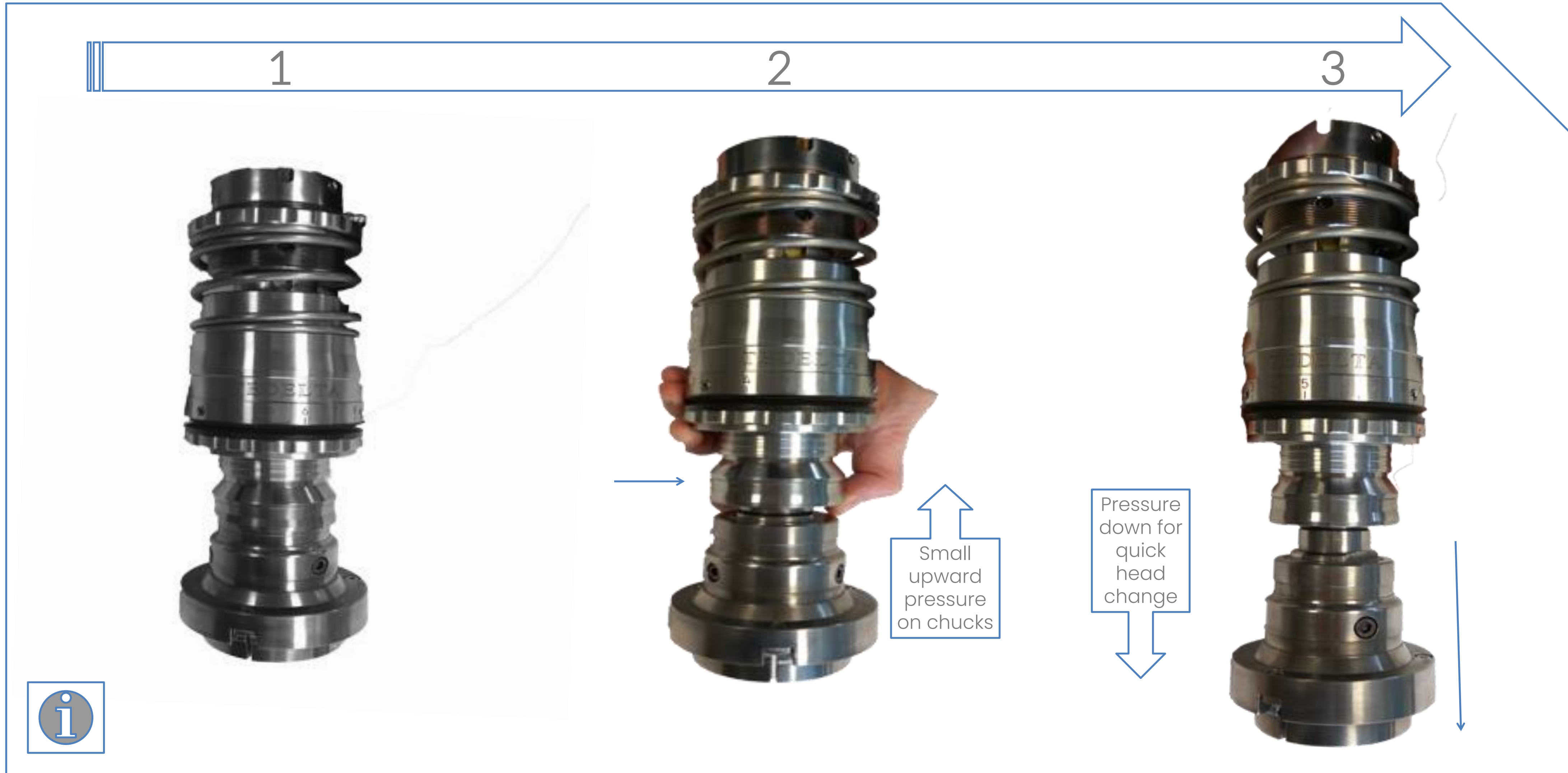
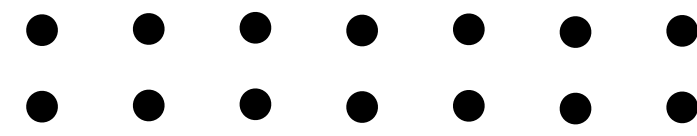

QUICK CHANGE RIGID CAPPING CHUCKS



A



B

Pressure
up on the
chuck

Pressure
down for
quick
head
change



C

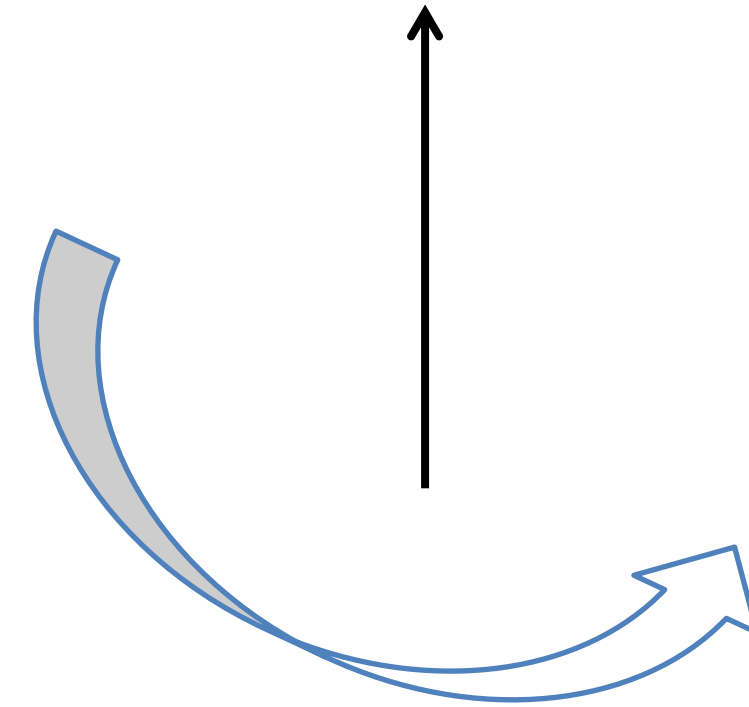
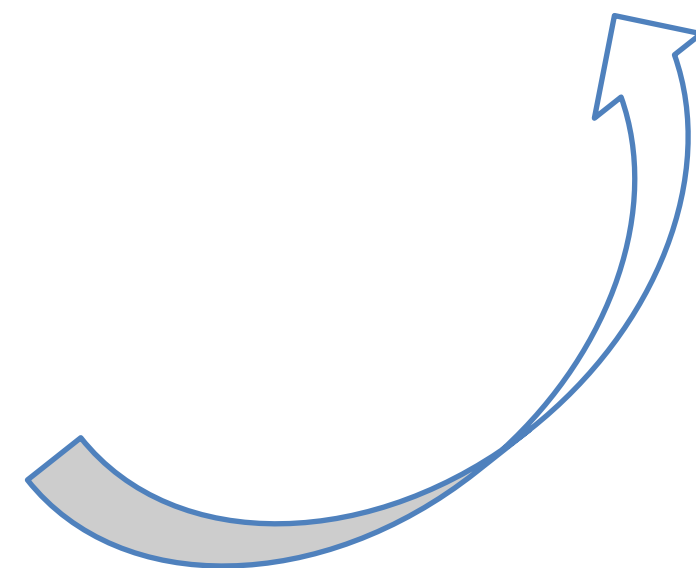

TEDELTA C.M. 706 T.R. GRIPPING SYSTEM



- Capping head equipped with gripping system to process flip top caps, oval caps....
- Adjustment of torque with optical reading.
- Outside spring allows top load adjustment easily.
- Quick-change chucks, no tools.

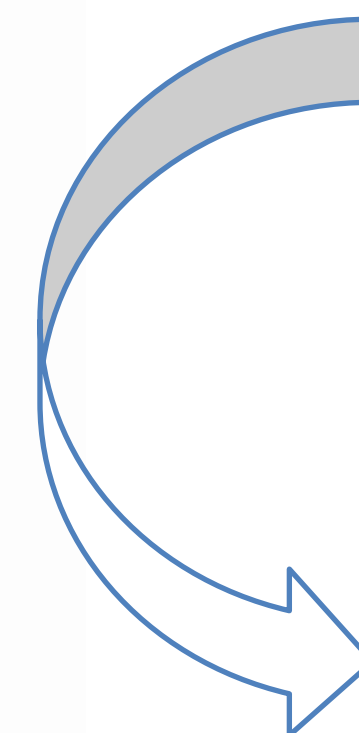
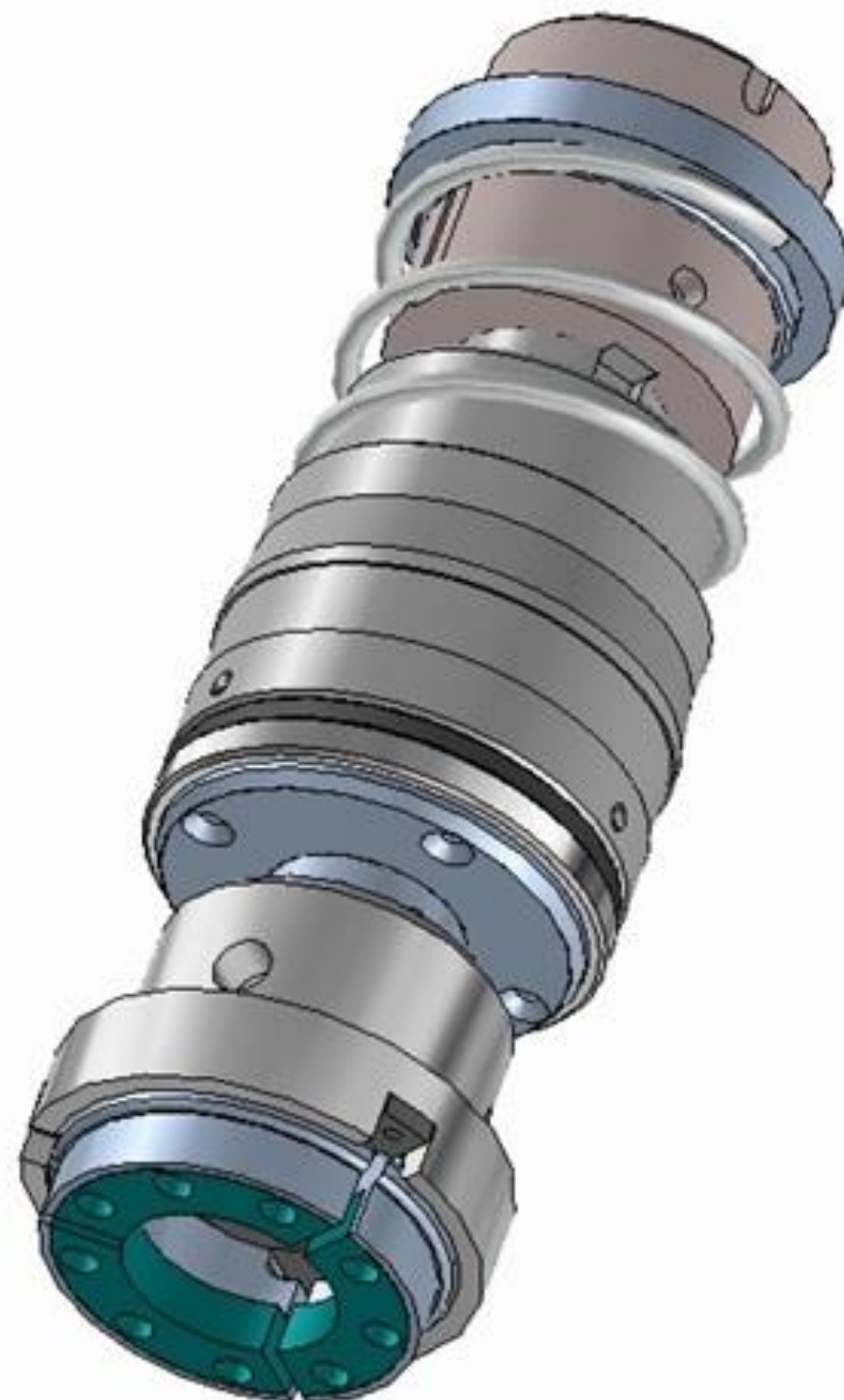

TEDELTA C.M. 706 T.R-PZ

GRIPPING SYSTEM

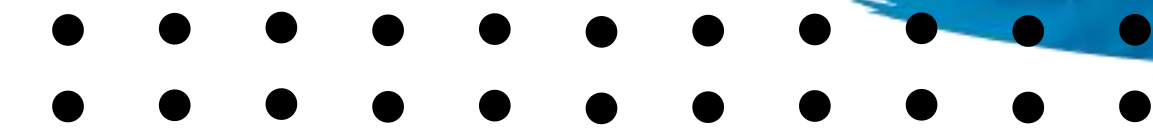

GRIPPING CAPPING SYSTEM

“C.M 706 T.R- PZ”.

Exclusive design according to application and product.

EXAMPLE:

Flip-top caps with torque control. (alimentation sector)

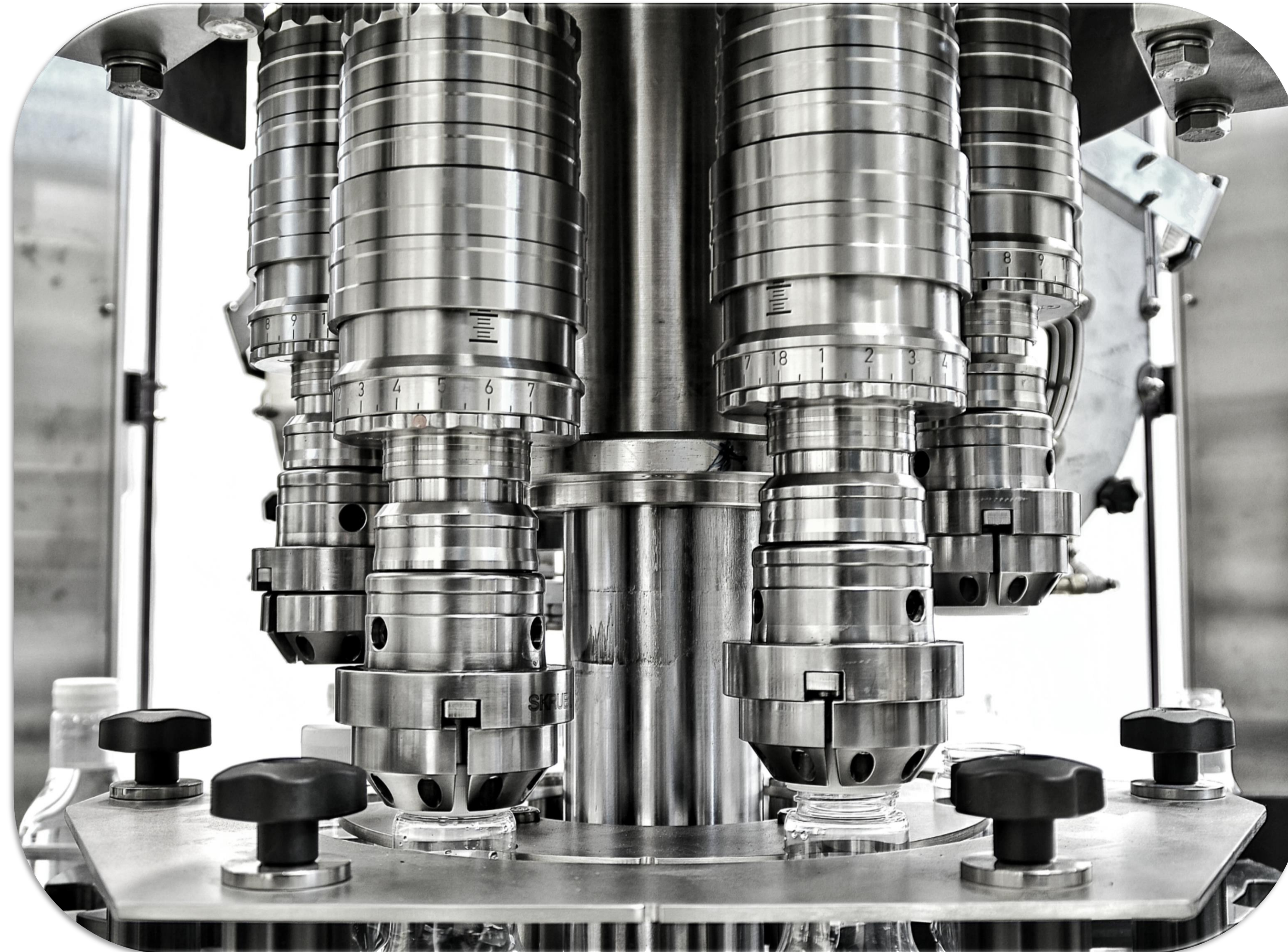

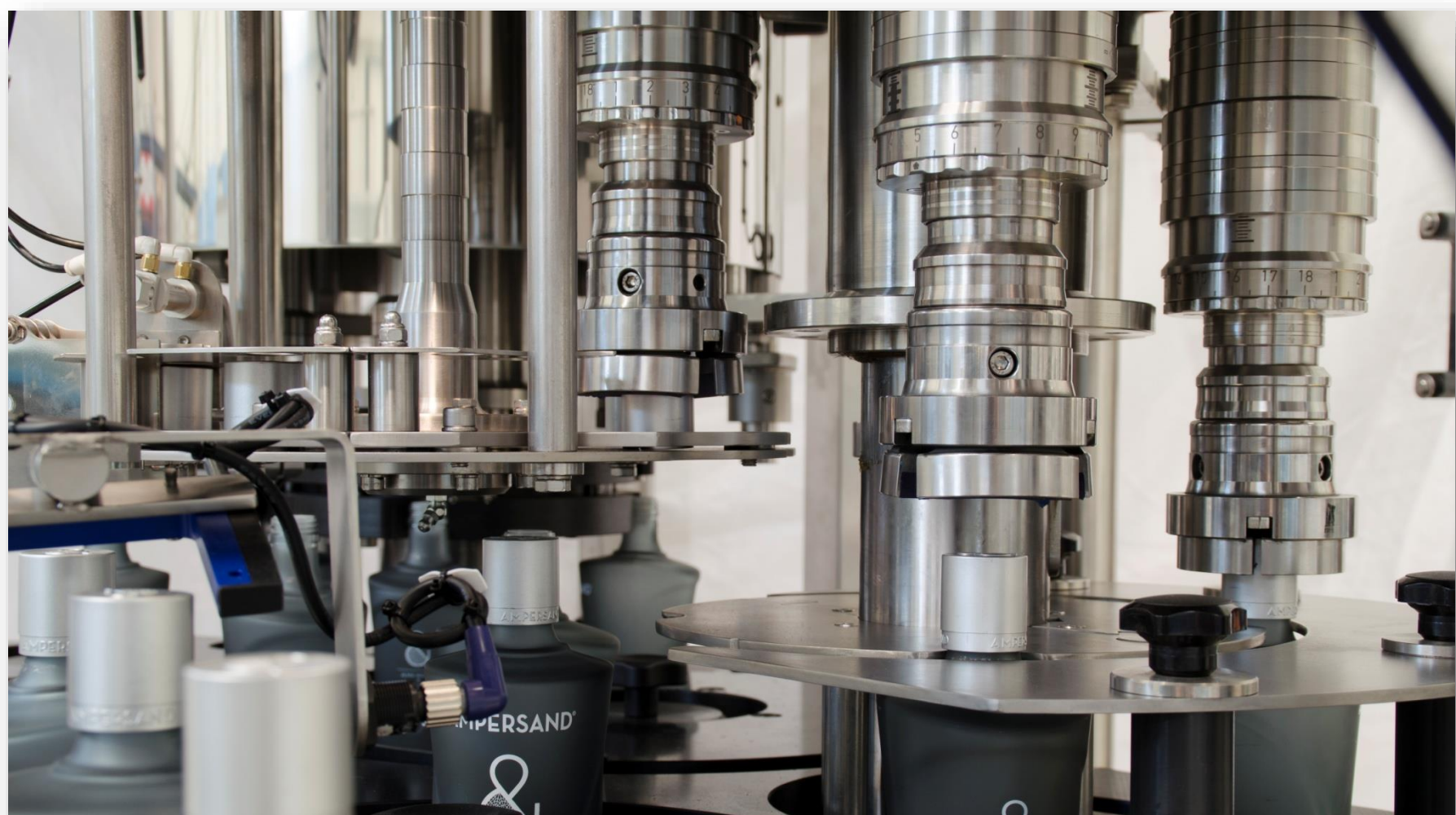
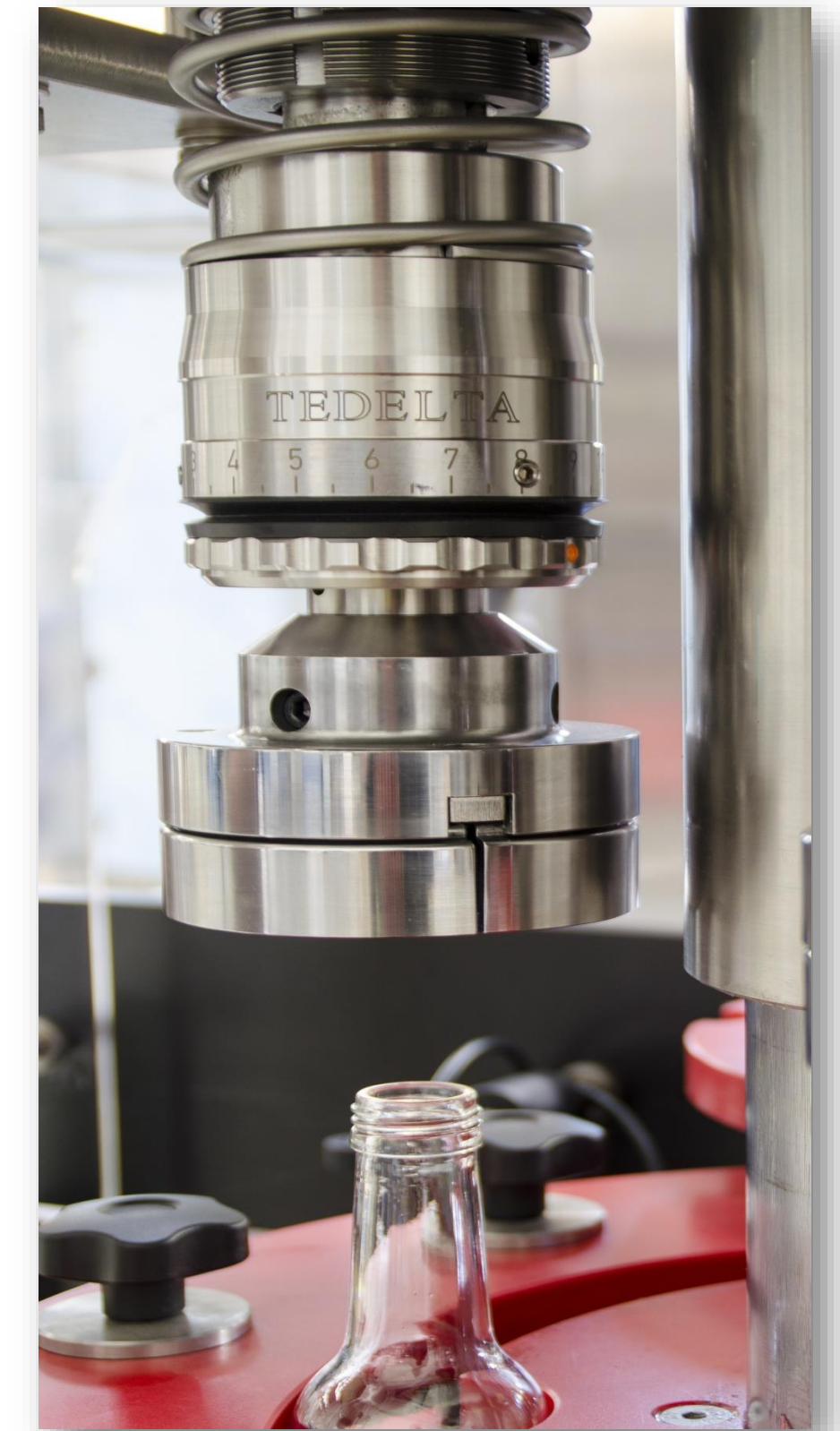
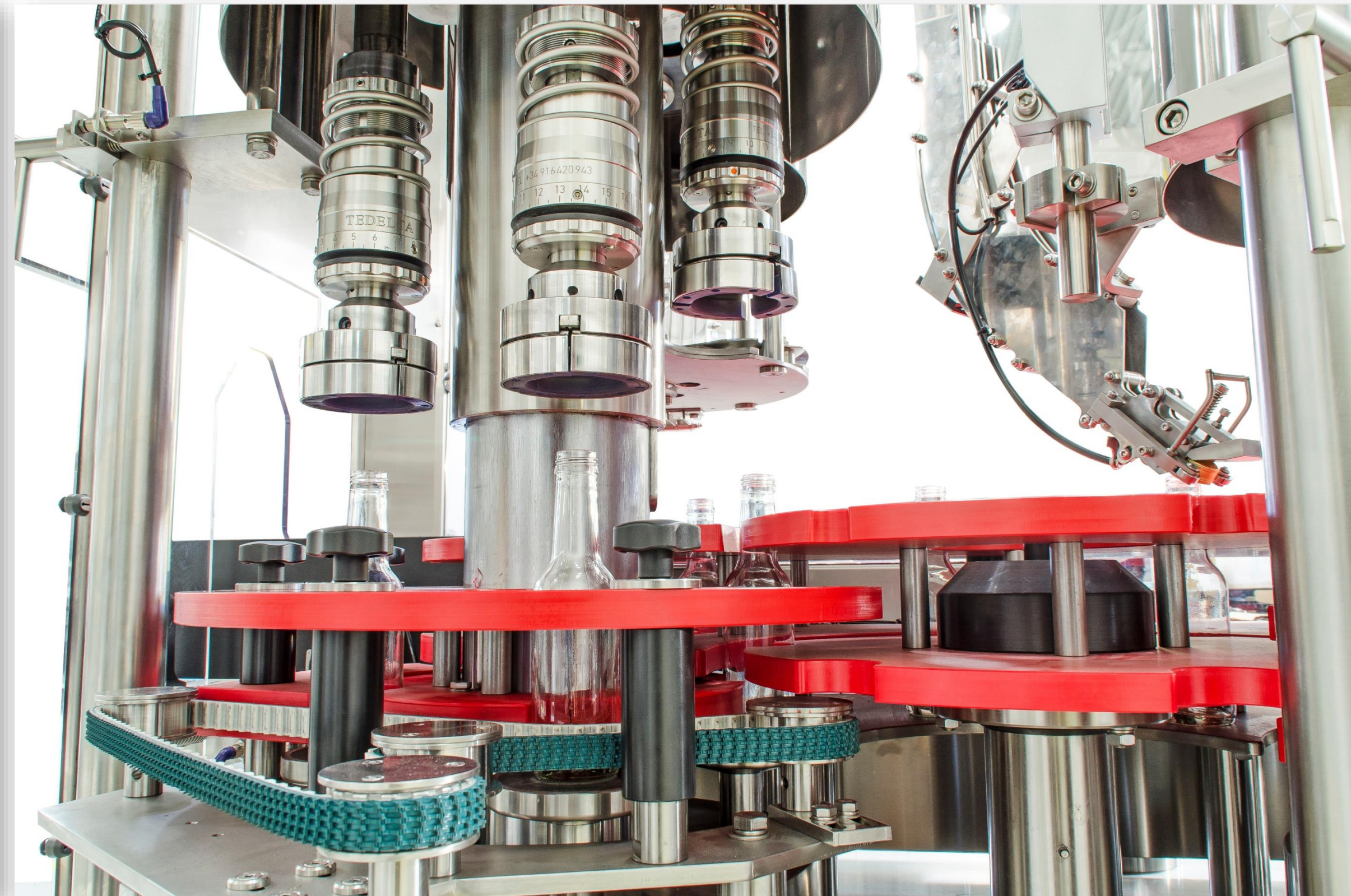

Details of cappers with magnetic head for different applications:

1. Pump cap
- 2 & 3. Plastic pre threaded cap
4. Over cap-push on cap in.
5. Identification of clamp chucks according to covers. 13

MAGNETICS CAPPING HEADS

CAPS APPLICATIONS

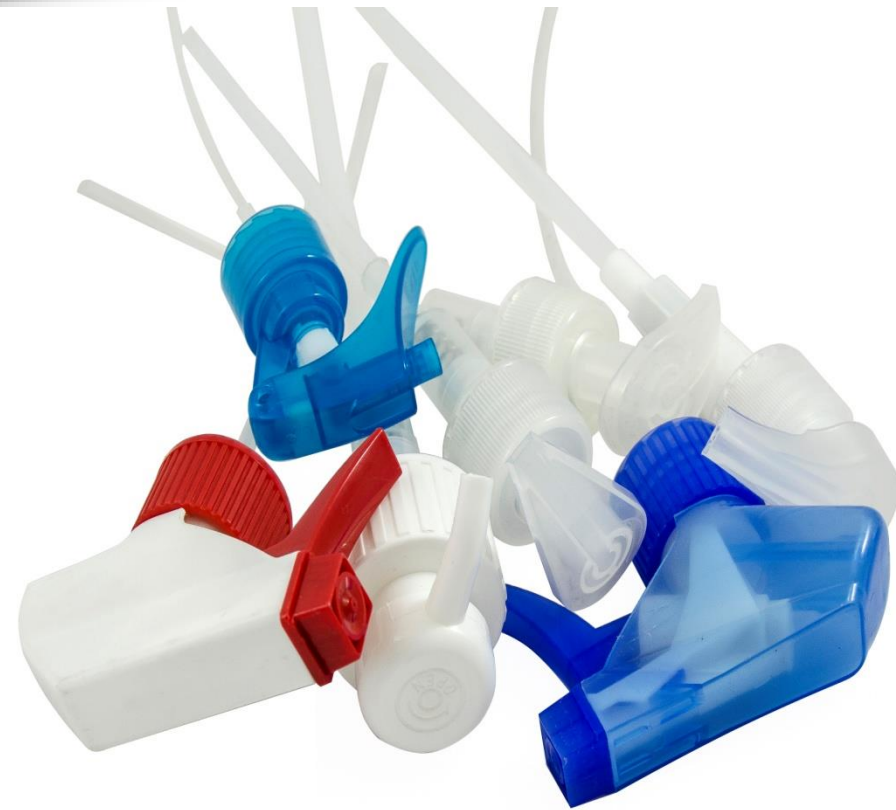

Trigger pump
Chemical sector
Cleaning products



Sport-cap
Pre-threaded caps
Beverage sector



Flip-top caps
Food industry



Chemical sector
Agri-food sector



Special caps
CosmeticSector

TEDELTA INTERNATIONAL

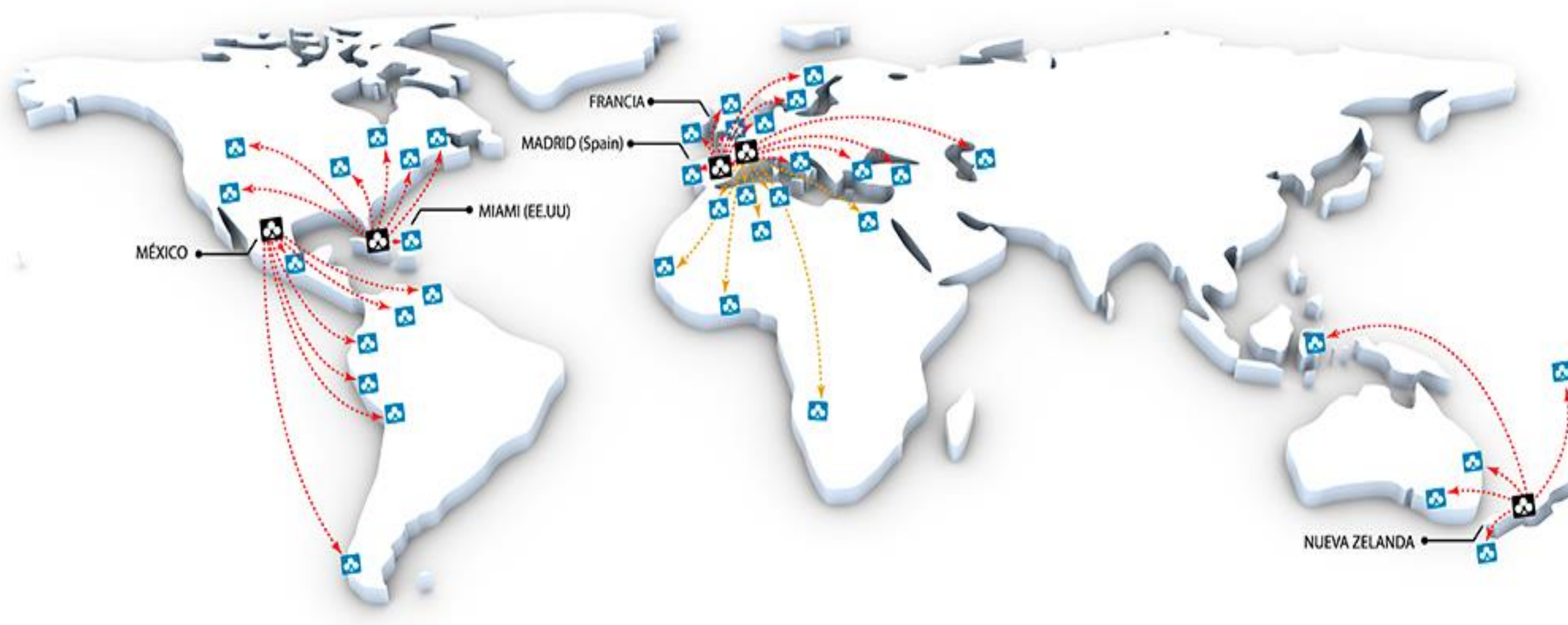

Our commitment to our clients pushes us to higher levels of Service. At Tedelta , we guarantee the fastest and highest quality service assistance, minimizing production downtimes and keeping possible technical problems and maintenance costs at the lowest levels possible.

Visit our machines working

Click Here:



In our you-tube channel you can visualize our machines and know the main technical characteristics of their performance as well as operative videos in operation.

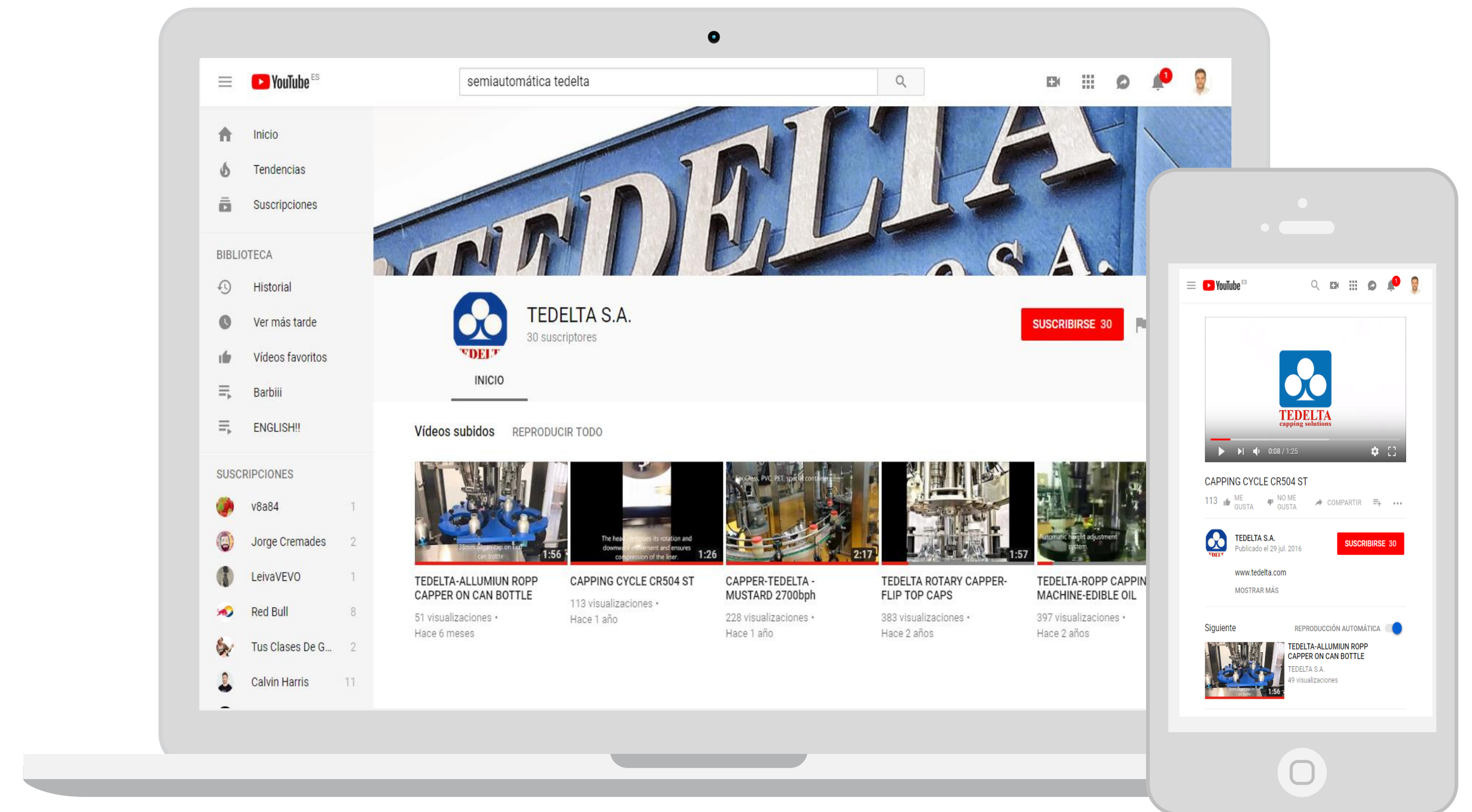

Stay in touch with Us

TEDELTA SPAIN

TLF:+34 91 642 09 43

EMAIL:

COMERCIAL@TEDELTA.ES

ALCOTANES, 29, 28320

PINTO, MADRID

ESPAÑA

TEDELTA NORTH AMÉRICA

EMAIL:

SALES.NORTHAMERICA@TEDELTA.COM

2335 suite R 63 rd Ave.E,

FI,34203

UNITED STATES

TEDELTA

WESTERN REGIONAL OFFICE

TLF: +1 916 626 7688

EMAIL:

TERRY.DYET@TEDELTA.COM

PO BOX 1373

Lincoln, CA 95648

UNITED STATES

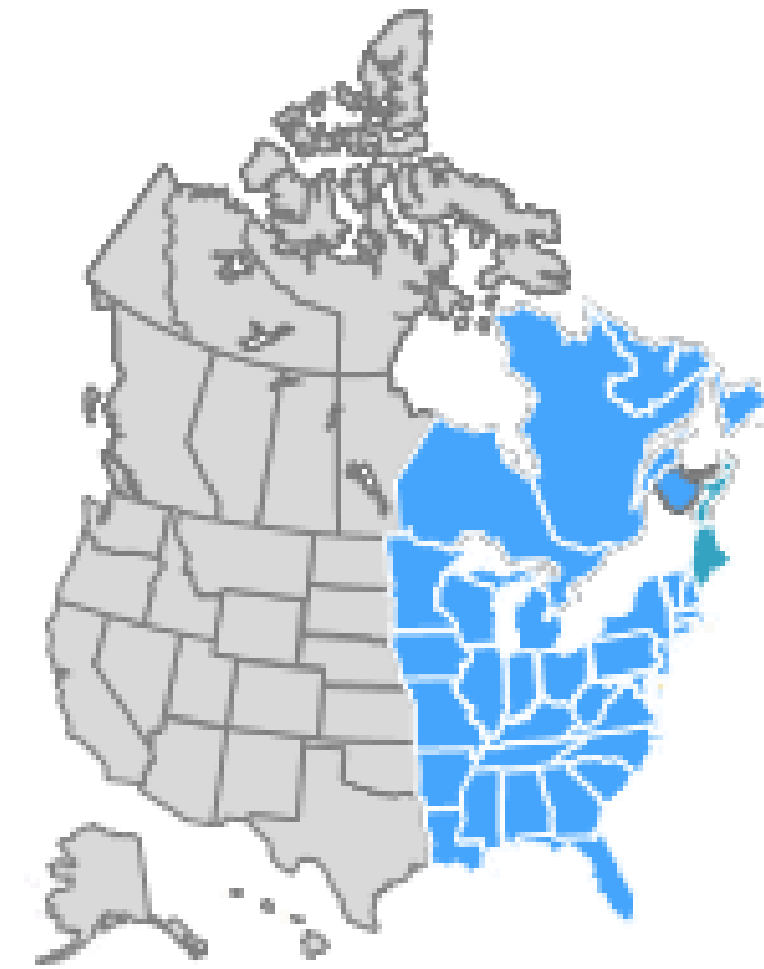

EASTERN REGIONAL OFFICE

TLF: +1 407 399 1986

EMAIL:

ANDY.COWEN@TEDELTA.COM

325 Seminole Woods Blvd.

Geneva, FL. 32732

UNITED STATES

